

Side Thrust Pins

Aluminum, without Pressure Pin, Press-On Type

SPECIFICATION

- 1 Housing Aluminium blank
- 2 Thrust plate with female thread hardened, blackened
- 3 Thrust spring coding
- 4 Force, low thrust: grey
- 5 medium thrust: lack
- 6 high thrust: silver
- 7 Seal rubber
- 8 NBR (Perbunan)

INFORMATION

Side thrust pins GN 714 are the result of further development of GN 715 (see page 860). It is left to the customer to design his own pressure pin which can be screwed into the thrust plate. This design extends the field of applications for side thrust pins offering identical advantages i.e. they eliminate costly alternatives, are space saving and are simple to install. The knurled body requires bore to H8 tolerance only. For easy mounting a suitable tool GN 715.1 is available (see table).

ACCESSORY

- Mounting tools GN 715.1 (Code no. see table)

TECHNICAL INFORMATION

- ISO-Fundamental Tolerances (see page A21)
- Elastomer characteristics (see page A32)

TECHNICAL AND ASSEMBLY INSTRUCTIONS

w = Movement of pin
 F = Side thrust in N
 initial thrust = F_0
 end thrust = $1.1 \times F_0$
 $a_2 - a_1$ = Clamping range for workpiece
 x = Distance centre line – thrust point at w_2
 x_1 for highest thrust point (a_1)
 x_2 for lowest thrust point (a_2)
 l_0 = Distance end stop – bore of thrust bushing
 $l_0 = l_m + x$
 l_m = Average length of workpiece $(l_{max.} + l_{min.}) / 2$
 For contact points (workpiece height) between a_1 and a_2 a value for x has to be used lying between x_1 and x_2 (interpolation).

By observing the above values the full movement of the side thrust pin will be available to cover the tolerance of the workpiece.



By observing the above values the full movement of the side thrust pin will be available to cover the tolerance of the workpiece.

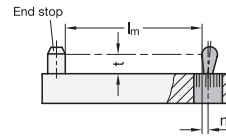

For inserting the side thrust pins the use of a mounting tool GN 715.1 or spanner GN 713.1 is recommended.

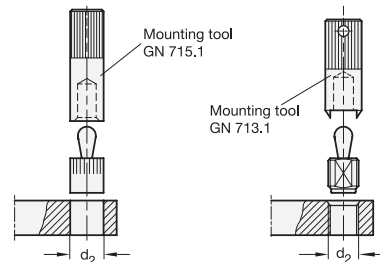

Eccentric bushes GN 715.2 (see page 867) are tooling accessory for GN 714 (see page 862) / GN 715 (see page 860). They enable a precise optimum setting of side thrust pins. This allows an adjustment to l_0 to accommodate for instance a larger tolerance range on a workpiece.

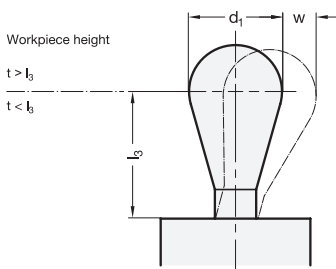
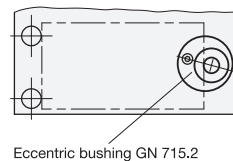

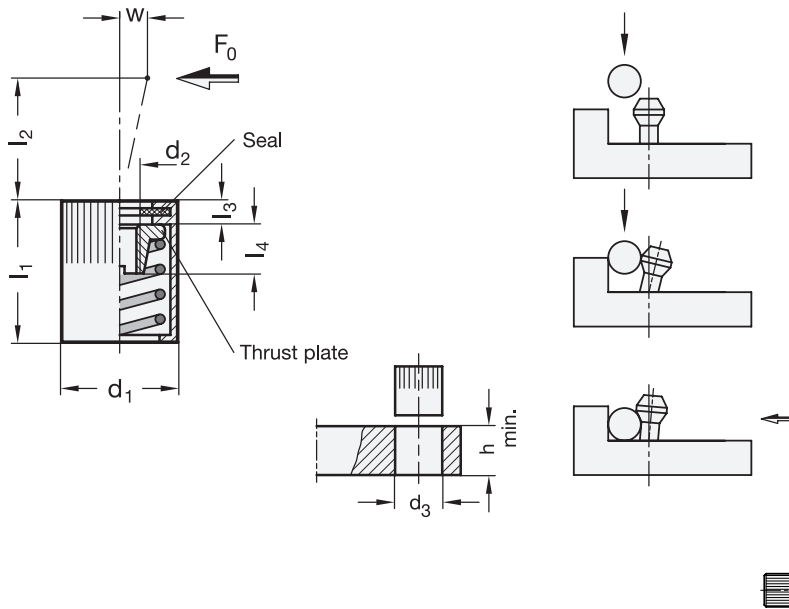

GN 714

Description	d1	Side thrust F0 in N ≈ at l2	d2	d3 H8	h min.	l1 -1	l2	l3	l4	w	Code no.	⚖
GN 714-10-20	10	20	M 4	10	12	12	4	1.5	4.5	1.6	GN 715.1-5.6	2
GN 714-10-40	10	40	M 4	10	12	12	7.5	1.5	4.5	1.6	GN 715.1-5.6	2
GN 714-10-50	10	50	M 4	10	12	12	4	1.5	4.5	1.6	GN 715.1-5.6	2
GN 714-10-75	10	75	M 4	10	12	12	7.5	1.5	4.5	1.6	GN 715.1-5.6	2
GN 714-10-100	10	100	M 4	10	12	12	4	1.5	4.5	1.6	GN 715.1-5.6	2
GN 714-10-150	10	150	M 4	10	12	12	7.5	1.5	4.5	1.6	GN 715.1-5.6	2
GN 714-16-100	16	100	M 6	16	18	18	11.5	2	7.5	3.2	GN 715.1-10	9
GN 714-16-200	16	200	M 6	16	18	18	11.5	2	7.5	3.2	GN 715.1-10	9
GN 714-16-300	16	300	M 6	16	18	18	11.5	2	7.5	3.2	GN 715.1-10	10

